

WILFLEY[®]

HEAVY DUTY CENTRIFUGAL PUMPS

Supplemental Assembly Manual

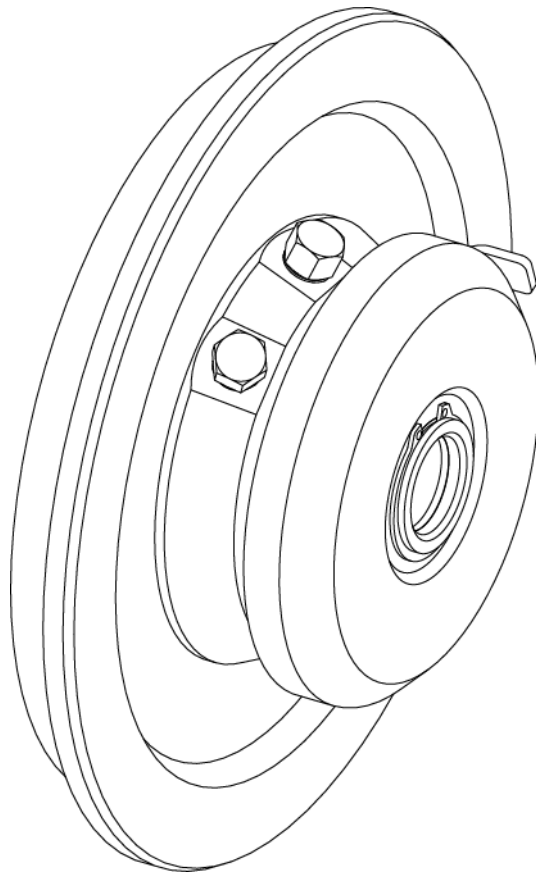

DryLock[®] 2 Static Seal Cartridge

Foreword

This manual contains instructions and guidelines for the assembly of the Wilfley DryLock® 2 static seal cartridge. There are many factors affecting the successful assembly of a seal cartridge, which makes it impossible to create a manual that covers all situations. Therefore, the information contained herein is meant to serve only as a general guideline. If detailed questions or problems arise, contact Wilfley or your authorized Wilfley representative.

Supplemental manuals may be required depending on the configuration of the pump.

It is extremely important that this entire manual be read prior to installation or start-up of the pump.

Use of the equipment on a service other than what was outlined at the time of purchase could void the warranty, unless Wilfley has been consulted and provided written approval in advance.

To assure proper installation, supervision from an authorized Wilfley representative is recommended.

A.R. Wilfley and Sons, Inc. shall not be liable for damage or delays caused by a failure to observe the instructions that are contained in this manual.

Warranty is only valid when genuine Wilfley parts are used. Contact your authorized Wilfley representative for basic warranty information and before making any changes.

About This Manual

The overall design of the DryLock® 2 static seal is very similar between the A7 and A9 chemical pumps. However, the items numbers of the components differ between the two models. Both sets of item numbers have been included in this manual, see below for more details.

Tables

A9 item numbers are referenced in the first column and A7 item numbers in the second column:

ITEM NO.		QTY.	DESCRIPTION
A9	A7		
7B	26	1	Seal Cartridge

A9 **A7**

Drawings

A9 item numbers are referenced in the top half of the callout and A7 item numbers in the bottom half:

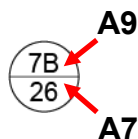

Instructions

A9 item numbers are referenced first and A7 item numbers second:

...seal cartridge (7B / 26)...

A9 **A7**

Table of Contents

1.0 Stationary Seal Subassembly.....	7
2.0 Shaft Sleeve Subassembly.....	8
3.0 Rotary Seal Subassembly	9
4.0 Ball Housing Subassembly.....	10
5.0 Final Assembly	11
5.1 Step 1	11
5.2 Step 2	12
6.0 DryLock® 2 Seal Adjustment	13
7.0 Cross Section (Standard Configuration).....	14
8.0 Revision History.....	15

1.0 Stationary Seal Subassembly

ITEM NO.		QTY.	DESCRIPTION
A9	A7		
7B	26	1	Seal Cartridge
7C	26H	1	Throttle Bushing
7D	23	1	Stationary Seal Ring
7E	30B	1	O-Ring, Stationary Seal Ring
7F	26J	1	O-Ring, Seal Cartridge

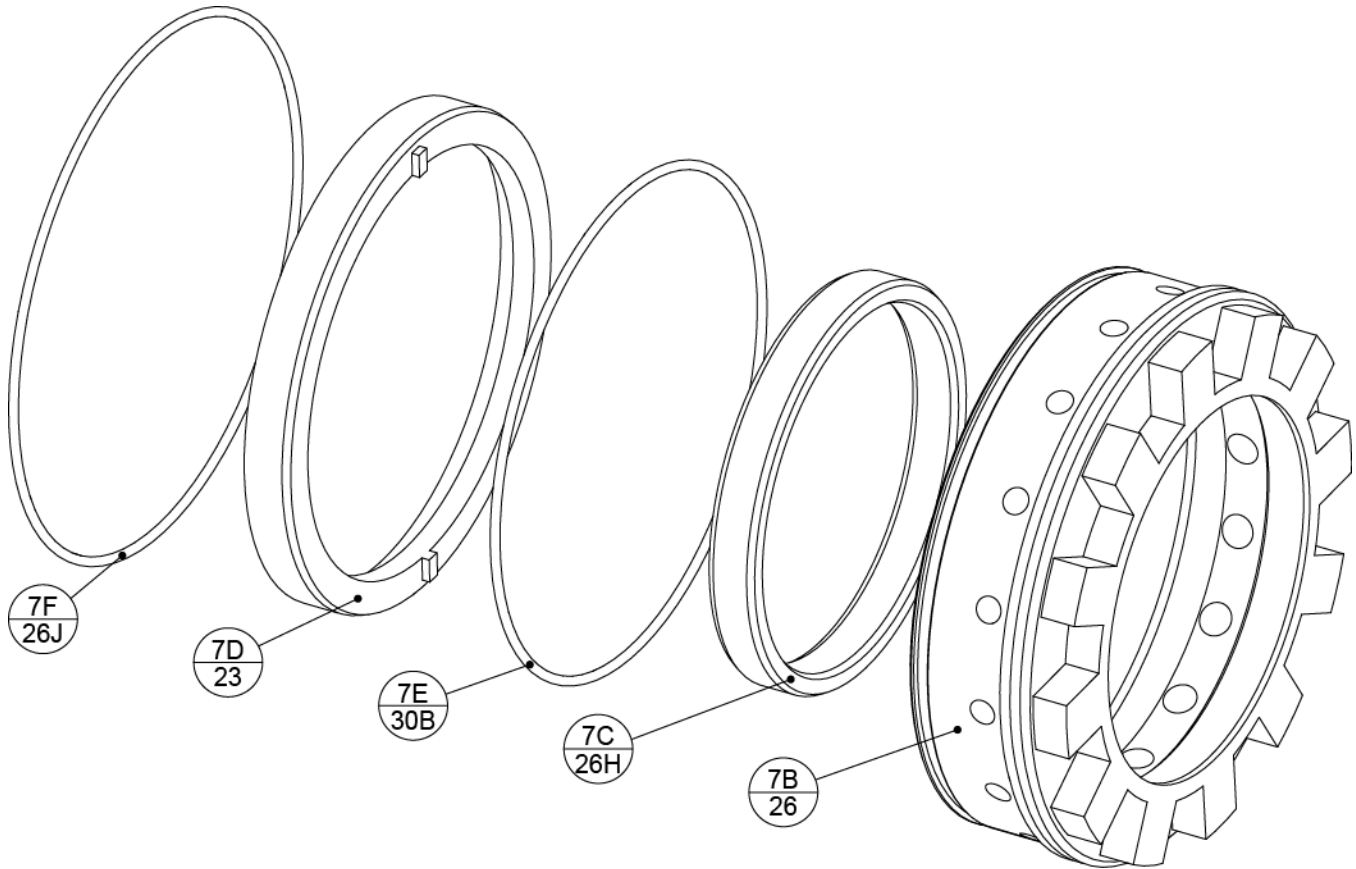

1. Press throttle bushing (7C / 26H) into the bore of the seal cartridge (7B / 26).
2. Install o-ring (7E / 30B) into the bore of the seal cartridge (7B / 26).
3. Press stationary seal ring (7D / 23) into the seal cartridge (7B / 26) by hand. Use lubrication if needed.
4. Install o-ring (7F / 26J) into the outer diameter groove of the seal cartridge (7B / 26).

2.0 Shaft Sleeve Subassembly

ITEM NO.		QTY.	DESCRIPTION
A9	A7		
4F	34C	1	Square Key
5A	39	1	Shaft Sleeve
5C	20	1	O-Ring, Shaft Sleeve
5J	42	1	DryLock® Spring
5Q	24A	1	O-Ring, Seal Sleeve
5R	18	1	O-Ring, Expeller

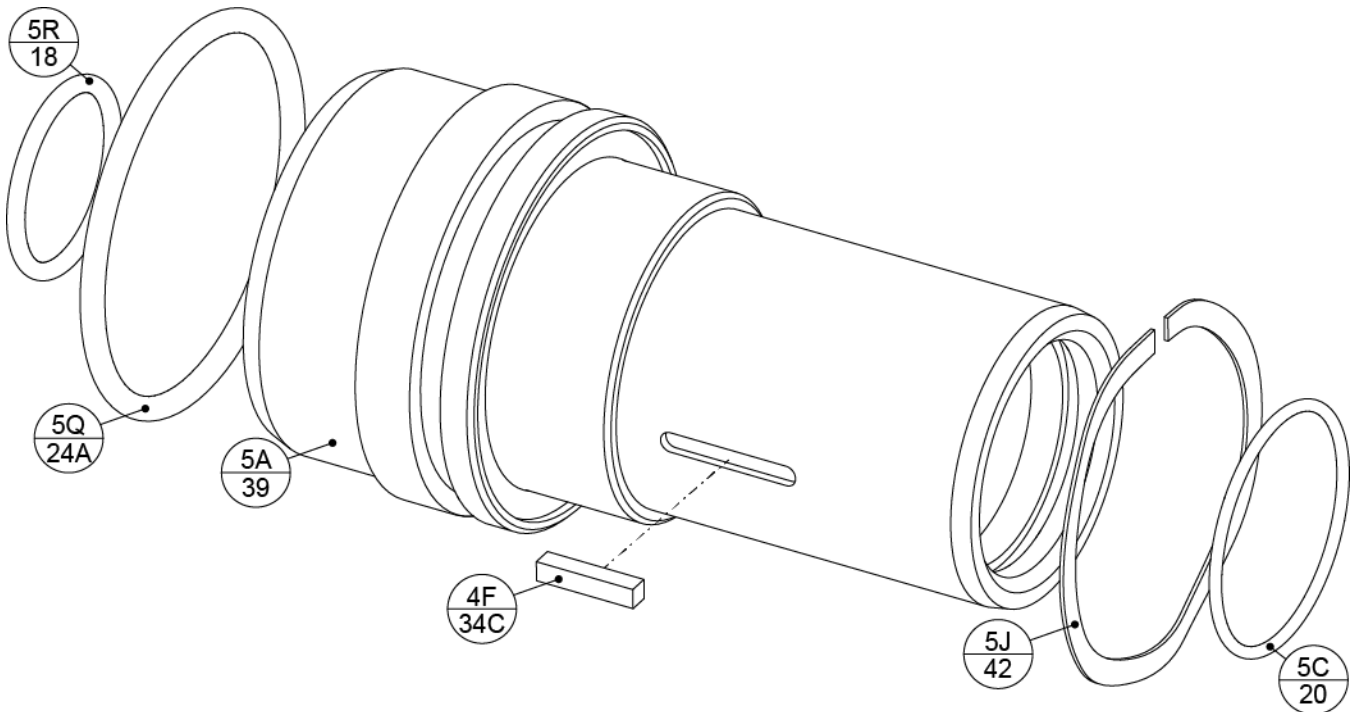

1. Install o-ring (5Q / 24A) into the outer diameter groove of the shaft sleeve (5A / 39).
2. Install o-ring (5R / 18) into the bore of the shaft sleeve (5A / 39).
3. Install o-ring (5C / 20) into the bore of the shaft sleeve (5A / 39).
4. Install spring (5J / 42) into the shaft sleeve (5A / 39).
5. Install key (4F / 34C) into the shaft sleeve (5A / 39).

3.0 Rotary Seal Subassembly

ITEM NO.		QTY.	DESCRIPTION
A9	A7		
5H	24J	1	Rotary Seal Sleeve
5K	24B	1	Slide Ring

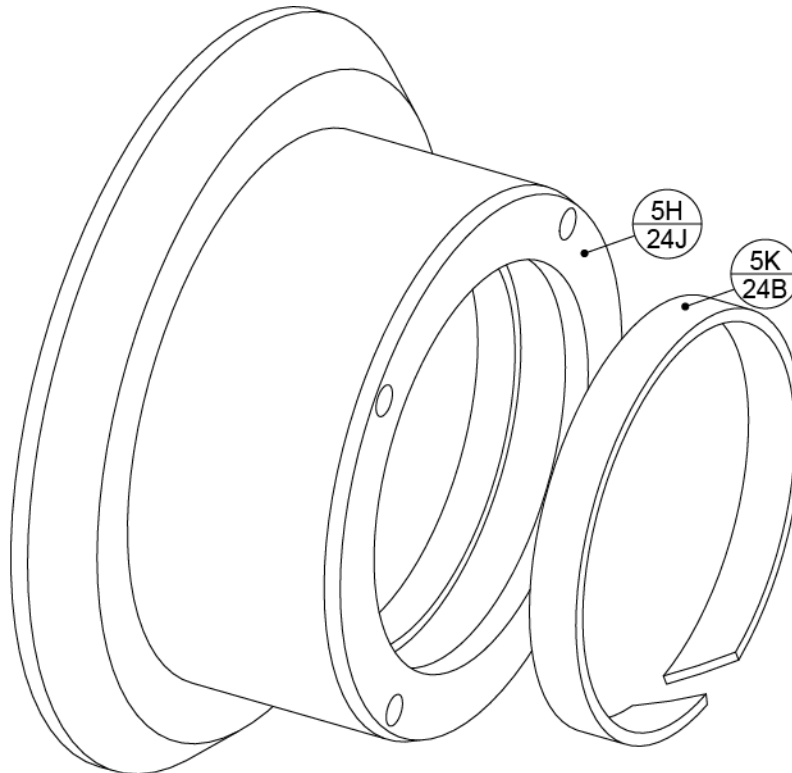

1. Install slide ring (5K / 24B) into the bore of the rotary seal sleeve (5H / 24J).

4.0 Ball Housing Subassembly

ITEM NO.		QTY.	DESCRIPTION
A9	A7		
4A	34	1	DryLock® Ball Housing
4B	40	1	Ball Retainer
4C	40A	TBD	Ball
4D	34A	1	Retaining Ring
4E	34B	1	Spring Pin

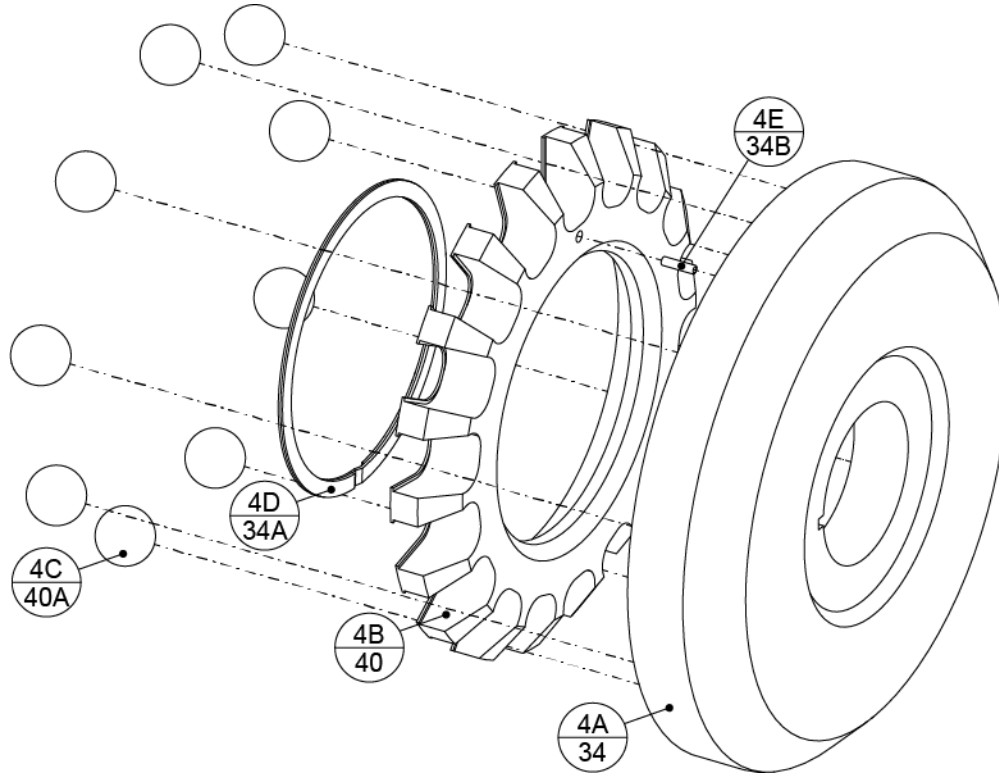

1. Install spring pin (4E / 34B) in the ball housing (4A / 34).
2. Install ball retainer (4B / 40) in the ball housing (4A / 34) so that the hole lines up with the spring pin (4E / 34B).
3. Install the retaining ring (4D / 34A) in the ball housing (4A / 34) to hold the ball retainer (4B / 40) in place.
4. Push balls (4C / 40A) into the slots in the ball retainer (4B / 40). Ensure that the balls (4C / 40A) are symmetrically spaced in the ball retainer (4B / 40).

Quantity of balls based on operating speed:

950 RPM	1150 RPM	1450 RPM	1750 RPM	2950 RPM	3550 RPM
18	12	9	6	3	3

If you are using a variable frequency drive and are operating the pump at various speeds, use 18 balls

5.0 Final Assembly

5.1 Step 1

ITEM NO.		QTY.	DESCRIPTION
A9	A7		
7A	30	1	DryLock® Seal Housing
7G	31A	1	Lip Seal
7S	30S	1	Posi-Lock Pin
7T	30T	1	Posi-Lock Bolt

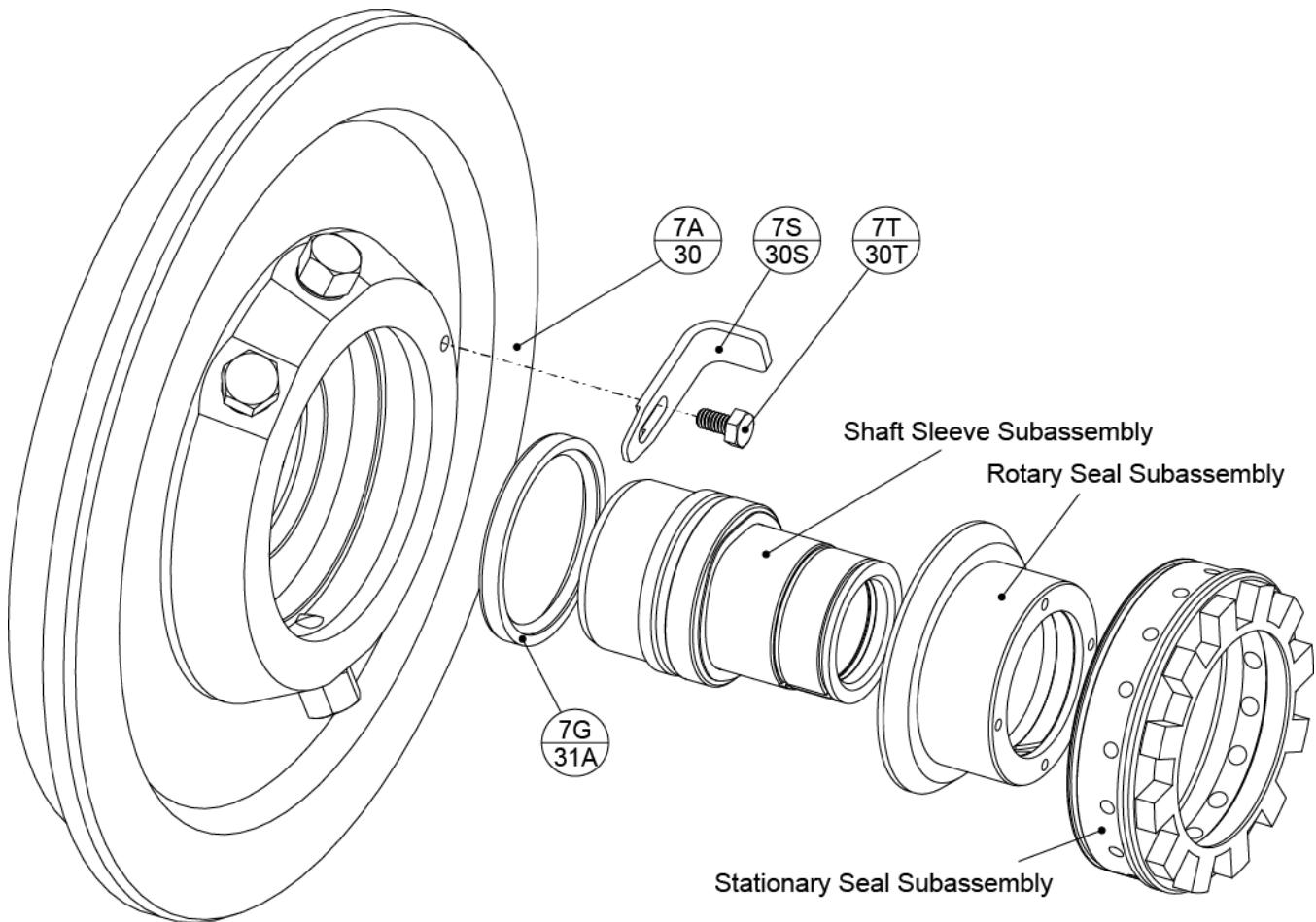

Ensure lip seal (7G / 31A) is installed in the correct direction:

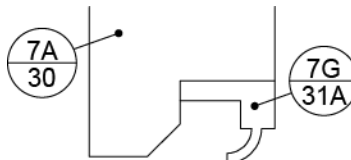

1. Press lip seal (7G / 31A) into the seal housing (7A / 30).
2. Install shaft sleeve subassembly in the seal housing (7A / 30).
3. Install rotary seal subassembly in the seal housing (7A / 30).
4. Loosely install stationary seal subassembly in the seal housing (7A / 30) keeping atleast one thread visible.
5. Loosely install posi-lock pin (7S / 30S) with posi-lock bolt (7T / 30T) on the seal housing (7A / 30).

5.2 Step 2

ITEM NO.		QTY.	DESCRIPTION
A9	A7		
5B	39A	1	Retaining Ring
5D	24C	4	Drive Screw
5E	24D	4	Drive Screw Sleeve
5F	43	1	Actuator Plate

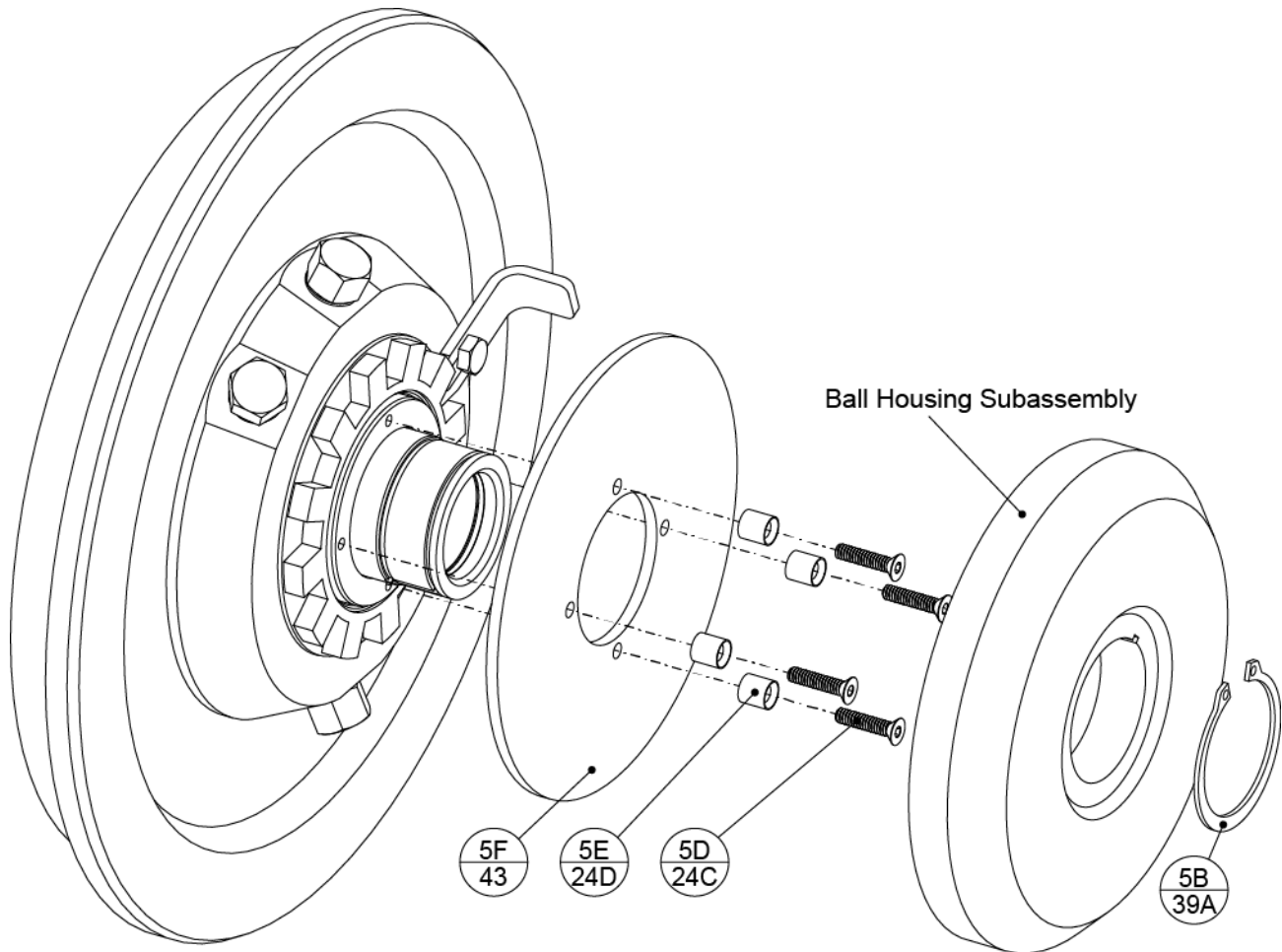

1. Install actuator plate (5F / 43) in the DryLock® 2 assembly.
2. Secure actuator plate (5F / 43) in the DryLock® 2 assembly with screws (5D / 24C) and sleeves (5E / 24D).
3. Install ball housing subassembly in the DryLock® 3 assembly.
4. Secure ball housing subassembly with retaining ring (5B / 39A).

****Assemble the pump and set the impeller clearance per the pump IOM****

6.0 DryLock® 2 Seal Adjustment

The seal **MUST** be adjusted and locked **AFTER** the pump has been assembled **AND** the impeller clearance has been set according to pump IOM.

1. Loosen bolt (7T / 30T) so pin (7S / 30S) slides freely. Pull pin out of seal cartridge (7B / 26) slot allowing the cartridge (7B / 26) to rotate freely.

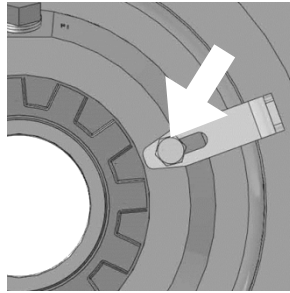

2. If not already done, using a 1/2" (Frame 4: 5/8") open ended wrench, loosen the seal cartridge (7B / 26) until approximately 1 full thread is visible.



3. Set the pump clearances according to the pump IOM.
4. Using the open ended wrench, tighten the seal cartridge (7B / 26) until you feel it bottom out solidly.
5. **Frame 1 & 2:** Using the open ended wrench, loosen the seal cartridge (7B / 26) a total of **4 tabs**. If you are halfway between tabs, loosen an additional tab.

Frame 3 & 4: Using the open ended wrench, loosen the seal cartridge (7B / 26) a total of **5 tabs**. If you are halfway between tabs, loosen an additional tab.

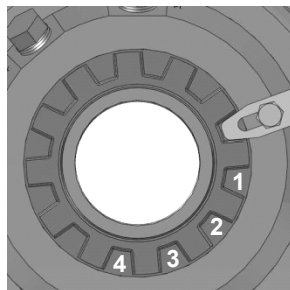

6. Insert the pin (7S / 30S) between the seal cartridge (7B / 26) to prevent rotation of the cartridge during pump operation. Tighten bolt (7T / 30T) so that the pin (7S / 30S) can no longer slide.

****The pump is now ready for use****

7.0 Cross Section (Standard Configuration)

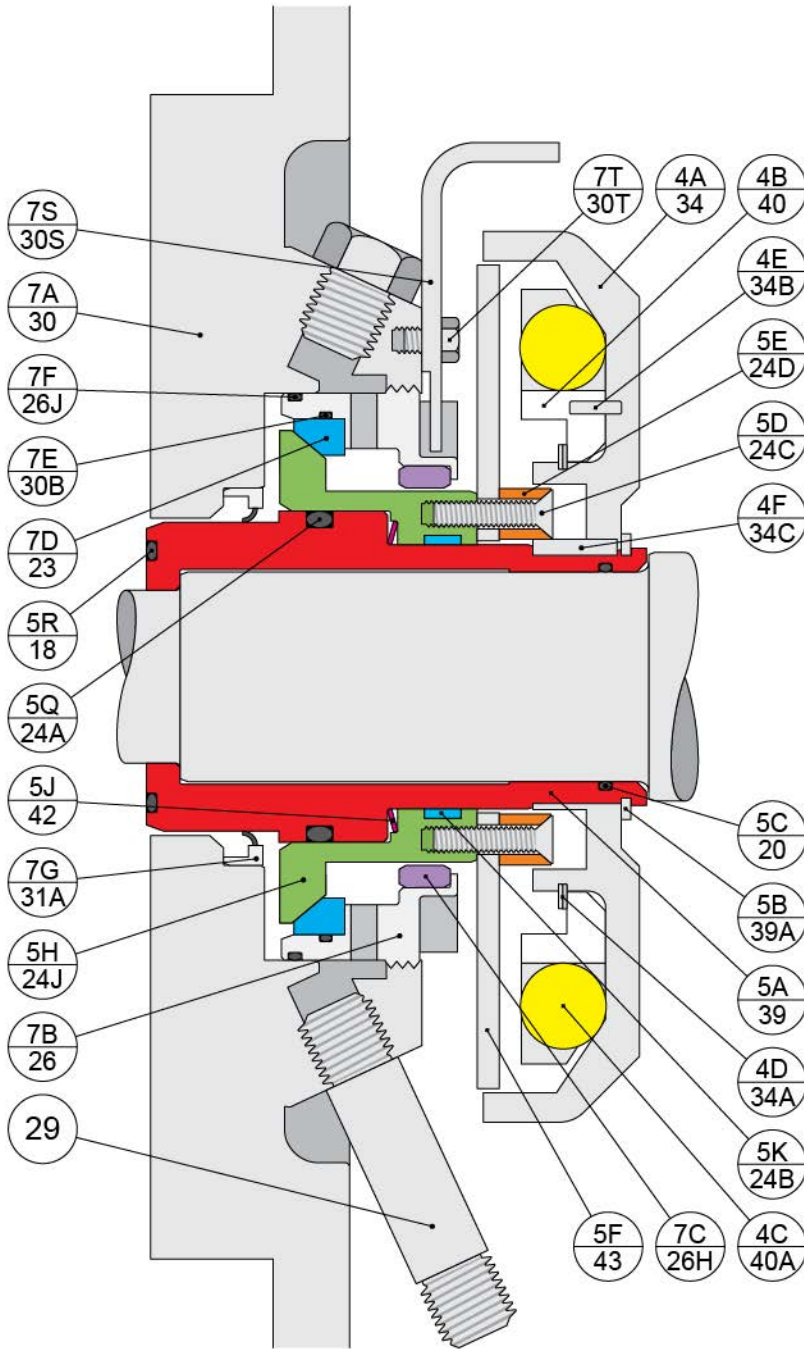

Item No.		Description	Qty.
A9	A7		
4A	34	DryLock® Ball Housing	1
4B	40	Ball Retainer	1
4C	40A	Ball	TBD ¹
4D	34A	Retaining Ring	1
4E	34B	Spring Pin	1
4F	34C	Square Key	1
5A	39	Shaft Sleeve	1
5B	39A	Retaining Ring	1
5C	20	O-Ring, Shaft Sleeve	1
5D	24C	Drive Screw	4
5E	24D	Drive Screw Sleeve	4
5F	43	Actuator Plate	1
5H	24J	Rotary Seal Sleeve	1
5J	42	DryLock® Spring	1
5K	24B	Slide Ring	1
5Q	24A	O-Ring, Seal Sleeve	1
5R	18	O-Ring, Expeller	1
7A	30	DryLock® Seal Housing	1
7B	26	Seal Cartridge	1
7C	26H	Throttle Bushing	1
7D	23	Stationary Seal Ring	1
7E	30B	O-Ring, Stationary Seal Ring	1
7F	26J	O-Ring, Seal Cartridge	1
7G	31A	Lip Seal	1
7S	30S	Posi-Lock Pin	1
7T	30T	Posi-Lock Bolt	1
29	29	Drain Spout	1

1. Quantity varies with pump size and operating speed.

8.0 Revision History

Revision	Description	Date
0	Initial Release	Sep. 2016